



*Adam Equipment*

## **CBC SERIES**

Software rev.: 1.3

© ADAM EQUIPMENT CO. LTD.  
p.n. 4284, Revision A, November 2003



# Contents

1. INTRODUCTION .....	2
2. SPECIFICATIONS.....	3
3. INSTALLATION .....	4
3.1 GENERAL INSTALLATION.....	4
3.2 INSTALLATION OF CBC SERIES .....	5
4. KEY DESCRIPTIONS .....	6
5. DISPLAYS .....	7
5.1 WEIGHT DISPLAY.....	7
5.2 UNIT WEIGHT DISPLAY .....	8
5.3 COUNT DISPLAY .....	8
6. OPERATION .....	8
6.1 ZEROING THE DISPLAY.....	8
6.2 TARING.....	9
6.3 PARTS COUNTING .....	10
6.3.1 Setting Unit Weight .....	10
6.3.2 Counting more parts.....	12
6.3.3 Automatic part weight updates .....	12
6.3.4 Count preset or Check-weighing .....	12
6.3.5 Manually Accumulated Totals .....	13
6.3.6 Automatic Accumulated Totals.....	13
7. PARAMETERS.....	14
8. CALIBRATION.....	15
9. RS-232 OUTPUT.....	17
10. BATTERY AND BACKLIGHT OPERATION .....	18
10.1 BATTERY.....	18
10.2 BACKLIGHT FOR LCD .....	19
11. ERROR CODES .....	20

## 1. INTRODUCTION

- The CBC series of scales provides an accurate, fast and versatile series of counting and check-weighing scales.
- There are 2 series of scales within the range-

**CBC** scales are kilogram only scales and the **CBCa** scales are changeable from pounds to kilograms. The scales in these series share the same functions but special instructions will be given for the CBCa series to account for the ability to change the weighing units.

- There are 4 models in each series with capacities up to 30 kg.
- They all have stainless steel weighing platforms on an ABS base assembly.
- All the keypads are sealed, colour coded membrane switches and there are three large, easy to read liquid crystal type displays (LCD). The LCD's are supplied with a backlight.
- All units include automatic zero tracking, audible alarm for pre-set weights, automatic tare, pre-set tare and an accumulation facility that allows the count to be stored and recalled as an accumulated total.

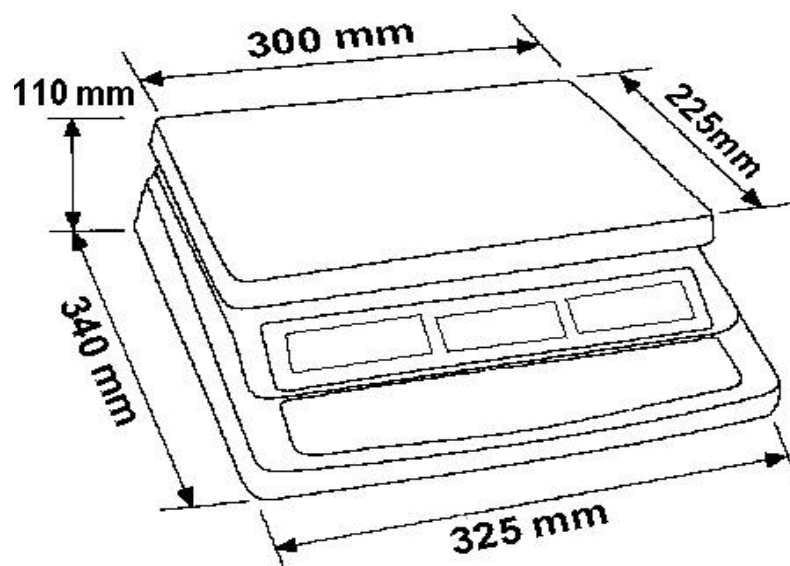

## 2. SPECIFICATIONS

<b>CBC SERIES</b>				
<b>Model #</b>	<b>CBC 3</b>	<b>CBC 6</b>	<b>CBC 15</b>	<b>CBC 30</b>
Maximum Capacity	3000 g	6000 g	15 kg	30 kg
Readability	0.1 g	0.2 g	0.5 g	1 g
Resolution	1:30.00	1:30.000	1:30.000	1:30.000
Tare Range	-3 kg	-6 kg	-10 kg	-30 kg
Minimum Capacity	2 g	4 g	10 g	20 g
Repeatability (Std Dev)	0.1 g	0.2 g	0.5 g	1 g
Linearity $\pm$	0.4 g	0.8 g	2 g	4 g
Units of Measure	g, kg			

<b>CBCa SERIES</b>				
<b>Model #</b>	<b>CBC 6a</b>	<b>CBC 12a</b>	<b>CBC 35a</b>	<b>CBC 65a</b>
Maximum Capacity	6lb / 3000 g	12 lb / 6000 g	35 lb / 15 kg	65 lb / 30 kg
Readability	0.0002 lb / 0.1 g	0.0005 lb / 0.2 g	0.001 lb / 0.5 g	0.002 lb / 1 g
Resolution	1:30.000	1:30.000	1:30.000	1:30.000
Tare range	-6lb / -3 kg	-10lb / -6 kg	-10lb / -10 kg	-65lb / -30 kg
Minimum Capacity	0.004 lb / 2 g	0.01 lb / 4 g	0.02 lb / 10 g	0.04 lb / 20 g
Repeatability (Std Dev)	0.0002 lb / 0.1 g	0.0005 lb / 0.2 g	0.001lb / 0.5 g	0.002 lb / 1 g
Linearity $\pm$	0.0008 lb / 0.4 g	0.0020 lb / 0.8 g	0.004 lb / 2.0 g	0.008 lb / 4 g
Units of Measure	kg,g,lb,oz			

<b>Common Specifications</b>	
Interface	RS-232 Output Optional
Stabilisation Time	2 Seconds typical
Operating Temperature	0°C - 40°C 32°F - 104°F
Power supply	9Vdc, 800ma Through an external adapter
Calibration	Automatic External
Display	3 x 6 digits LCD digital display 20mm digits
Balance Housing	ABS Plastic, Stainless Steel platform
Pan Size	225 x 300mm 8.9 x 11.8"
Overall Dimensions (wxdxh)	325 x 340 x 110mm 12.8 x 13.4 x 4.3"
Gross Weight	3.8 kg/8.4 lb
Applications	General Purpose Parts counting Scale
Functions	Kilogram weight, parts counting, accumulating memory, pre-set count with alarm
Other Features and Specs	Accuracy enhancement for parts counting, internal rechargeable battery (~70 hours operation)

## **3. INSTALLATION**

### **3.1 GENERAL INSTALLATION**

- Avoid extreme temperatures. Do not place in direct sunlight or near air conditioning vents. Avoid air movement such as from fans or opening of doors and windows.
- Avoid unsuitable tables. Do not place near vibrating machinery.
- Avoid unstable power sources while charging the battery. Do not use the scale near any large user of electricity such as welding equipment or large motors.
- Avoid high humidity that might cause condensation. Avoid direct contact with water. Do not spray or immerse the scales in water.
- Keep the weighing area clean.
- Do not stack material on the scale when not in use.
- **Protect the scale from temperature, vibration and dust.**

## 3.2 INSTALLATION OF CBC SERIES

- The CBC Series comes with a stainless steel platform packed separately.
- Place the platform in the locating holes on the top cover.
- Do not press with excessive force as this could damage the load cell inside.
- Level the scale by adjusting the four feet. The scale should be adjusted such that the bubble in the spirit level is in the centre of the level and the scale is supported by all four feet.
- Attach the power supply cable to the connector on the bottom of the right side of the scale. Plug in the power supply module. The power switch is located on the base on the right side of the scale.
- The scale will show the model no in the “**Weight**” display window (CBC 30- where 30 denotes the maximum capacity of the scale in Kg) and the current hardware and software revision numbers in the “**Unit Weight**” display window .

For example “**1.1-1.3**”: The first number “**1.1**” is the hardware revision number of the main circuit board and the next one “**1.3**” is the software revision number.

- Next a self-test is followed. At the end of the self-test, it will display “**0**” in all three displays, if the zero condition has been achieved.

## 4. KEY DESCRIPTIONS

Keys	Functions
[0-9, .]	Numeric entry keys, used to manually enter a value for tare weights, unit weight, and sample size.
[CE]	Used to clear the unit weight or an erroneous entry.
[M+]	Add the current count to the accumulator. Up to 99 values or full capacity of the weight display can be added. Also prints the displayed values when Auto print is switched off.
[MR]	To recall the accumulator memory.
[Pst]	To set the upper limit for the number of items counted. When this upper limit is exceeded the scale will sound the beeper.
[Print]	To print the accumulated totals to a PC or printer using the optional RS-232 interface.
[Smpl]	Used to input the number of items in a sample.
[U.Wt./Units]	Used to enter the weight of a sample manually.
[Tare]	Tares the scale. Stores the current weight in memory as a tare value, subtracts the tare value from the weight and shows the results. This is the net weight. Entering a value using the keypad will store that value as the tare value.
[Zero]	Set the zero point for all subsequent weighing. It shows zero.

### **CBCa SCALES ONLY**

[U. Wt//Units] key will also select the weighing unit when the “Unit Weight” display is at zero, apart from using this key to enter the weight of a sample manually like in CBC series (as mentioned above).



## 5. DISPLAYS

The scales have three digital display windows. These are “**Weight**”, “**Unit Weight**” and “**Count**”.

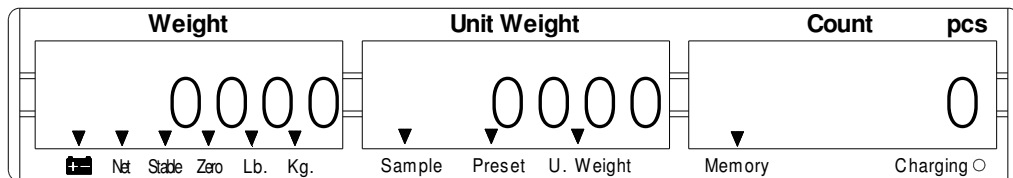

CBCa  
Type  
with lb/kg  
indicators

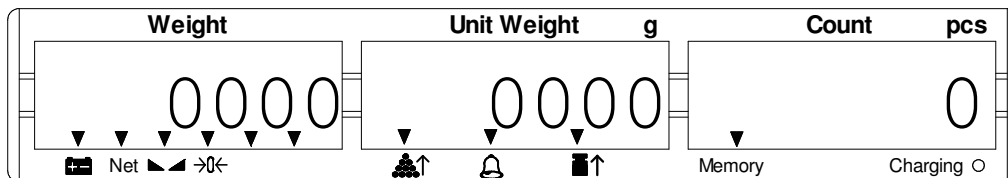

CBC  
Type  
with  
symbols

### 5.1 WEIGHT DISPLAY

It has 5-digit display to indicate the weight on the scale.

Arrows above symbols will indicate the following:

Low battery, 

Net Weight Display, "**Net**"

Stability indicator, "**Stable**"

Zero indicator, "**Zero**"

In the **CBCa** models, there will be additional indicators for the changed units i.e., "**lb**" or "**kg**".

## 5.2 UNIT WEIGHT DISPLAY

This display will show the unit weight of a sample. This value is either input by the user or computed by the scale. The unit of measurement is grams on all scales and in **CBCa** series of scales, it is kilogram or pounds.

The arrow indicator will be seen above "**Sample**" when there is insufficient number of samples to accurately determine the count.

When the unit weight is not large enough to determine an accurate count, the Indicator will be seen above "**U. Weight**".

In both cases the scale continues to operate and the indications are to alert the user for a potential problem.

If a preset count has been stored the "**Preset**" will have an arrow above it.

## 5.3 COUNT DISPLAY

This display will show the number of items on the scale or the value of the accumulated count. See OPERATION section.

The arrow indicator will be seen above "**Memory**" when a value has been entered into the memory.

# 6. OPERATION

## 6.1 ZEROING THE DISPLAY

- You can press the **[Zero]** key at any time to set the zero point from which all other weighing and counting is measured. This will usually only be necessary when the platform is empty. When the zero point is obtained the Weight display will show the indicator for zero.
- The scale has an automatic re-zeroing function to account for minor drifting or accumulation of material on the platform. However you may need to press **[Zero]** to re-zero the scale if small amounts of weight are shown when the platform is empty.

## 6.2 TARING

There are two methods to enter a tare value. The first uses the weight on the platform and the second uses a value input by the user.

### First Method:

- Zero the scale by pressing the **[Zero]** key if necessary. The indicator above “**Zero**” will be on.
- Place a container on the platform, a value for its weight will be displayed.
- Press the **[Tare]** key to tare the scale. The weight that was displayed is stored as the tare value and that value is subtracted from the display, leaving zero on the display. The indicator above “**Net**” will be on.
- As a product is added only the weight of the product will be shown. The scale could be tared a second time if another type of product was to be added to the first one. Again only the weight that is added after taring will be displayed.
- When the container is removed a negative value will be shown. If the scale was tared just before removing the container this value is the gross weight of the container plus all products those were removed. The indicator above “**Zero**” will also be on because the platform is back to the same condition as it was when the **[Zero]** key was pressed last.

### Second Method:

- This method allows you to enter a value for the tare weight from the keypad. This is useful if all containers are the same or if the container is already full but the net weight is required and the weight of the container is known.
- Remove all weights from the platform, press the **[Zero]** key to zero the display.
- Enter the value for the Tare weight including decimal point using the keypad and press **[Tare]** to store the tare value. The weight will show a negative value equal to the tare value.
- Place the container on the platform.

- The display will then show the weight of the container minus the tare weight.
- When the full container is placed on the platform the tare value will be subtracted from the gross weight displaying only the net weight of the contents.
- If the value input is not consistent with the increment of the scale, the tare value will be rounded off by the scale to the nearest value possible. For example, if a tare value of 10.3g is entered into the 6Kg/0.5g scale, then the display will show -10.5g.

***CBCa SERIES ONLY***

**SETTING THE WEIGHING UNIT, lb or kg**

The scale will turn on displaying the last weighing unit selected, either kilograms or pounds. To change the weighing unit press the **[U. Wt./Units]** key when the unit weight display shows zero. If necessary press the **[CE]** key to clear the unit weight before changing.

## **6.3 PARTS COUNTING**

### **6.3.1 Setting Unit Weight**

In order to do parts counting it is necessary to know the average weight of the items to be counted. This can be done by weighing a known number of the items and letting the scale determine the average unit weight or by manually inputting a known unit weight using the keypad.

#### **A. Weighing a sample to determine the Unit Weight**

- To determine the average weight of the items to be counted it will be necessary to place a known quantity of the items on the scale and then to key in the number of items being weighed.
- The scale will then divide the total weight by the number of items and display the average unit weight.
- Zero the scale by pressing the **[Zero]** key if necessary. If a container is to be used, place the container on the scale and tare as discussed earlier.

- Place a known quantity of items on the scale. After the weight display is stable, enter the quantity of items using the numeric keys followed by pressing the **[Smpl]** key.
- The number of units will be displayed on the "**Count**" display and the computed average weight will be shown on the "Unit Weight" display.
- As more items are added to the scale, the weight and the quantity will increase.
- If the scale is not stable, the calculation will not be completed. If the weight is below zero, the "**Count**" display will show negative count.

### **B. Entering a known Unit Weight**

- If the unit weight is already known then it is possible to enter that value using the keypad.
- Enter the value of the unit weight using the numeric keys followed by pressing the **[U. Wt./Units]** key. The "**Unit Weight**" display will show the value as it was entered.
- The sample is then added to the scale and the weight will be displayed as well as the quantity based upon the unit weight.
- When weighing in kilograms the unit weight is shown in grams. When weighing in pounds the unit weight is in pounds.

#### ***CBCa Series only:***

The **[U. Wt./Units]** key has a dual function. When the scale is at zero and the "**Unit Weight**" display is showing zero, pressing this key will change the scale from pounds to kilograms or vice-versa. When a value is entered into the "**Unit Weight**" display, the unit changing function is not active and the scale will automatically use the entered value for the unit weight. If the next key is not pressed within 5 seconds then the information in the "**Unit Weight**" display is cleared and the unit changing function is active again.

### 6.3.2 Counting more parts

- After the unit weight has been determined or entered it is possible to use the scale for parts counting. The scale can be tared to account for package weight as discussed in the earlier section.
- After the scale is tared then the items to be counted are added and the "**Count**" display will show the number of items computed using the weight and the unit weight.
- It is possible to increase the accuracy of the unit weight at any time during the counting process by entering the count displayed and then pressing the **[Smpl]** key. You must be certain that the quantity displayed matches the quantity on the scale before pressing the key. The unit weight will be adjusted based upon a larger sample quantity. This will give greater accuracy when counting larger sample sizes.

### 6.3.3 Automatic part weight updates

- The scales will automatically update the unit weight when a sample equal to less than the sample already on the platform is added. A beep will be heard when the value is updated. It is wise to check the quantity is correct when the unit weight has been updated automatically.
- This feature is turned off as soon as the number of items added exceeds the count used as a sample.

### 6.3.4 Count preset or Check-weighing

- Check-weighing (Count Pre-setting) is a procedure to cause an alarm to sound when the number of items counted on the scale meets or exceeds a number stored in the memory by using the **[Pst]** key.
- The stored value is entered from the keyboard. Enter the numeric value to be stored using the numeric keys. Then press the **[Pst]** key to store the value.
- To clear the value from the memory and thereby turn off the check-weighing feature, enter the value "**0**" and press **[Pst]**.

### 6.3.5 Manually Accumulated Totals

- The values (weight and count) shown on the display can be added to the values in the accumulator by pressing the **[M+]** key. The "**Weight**" display will show the total weight, the "**Count**" display will show the total accumulated count and the "**Unit Weight**" display shows the number of times, the items have been added to the memory for accumulation. The values will be displayed for 2 seconds before returning to normal.
- The scale must return to zero or a negative number before another sample can be added to the memory.
- More products can then be added and the **[M+]** key to be pressed again. This can continue for up to 99 entries or until the capacity of the "**Weight**" display is exceeded.
- To observe the total stored value, press the **[MR]** key. The total will be displayed for 2 seconds.
- To clear the memory- press **[MR]** to recall the totals from memory and then press the **[CE]** key to clear all values from the memory.

### 6.3.6 Automatic Accumulated Totals

- The scale can be set to automatically accumulate totals when a weight is placed on the scale. This eliminates the need to press the **[M+]** key to store values into the memory. However the **[M+]** key is still active and can be pressed to store the values immediately. In this case the values will not be stored when the scale returns to zero.
- See the PARAMETERS Section for details on how to enable Automatic Accumulation.

## 7. PARAMETERS

- To set the parameters it is necessary to enter a secure menu. This is done by entering a password number when requested.
- To enter the parameter menus press the **[Tare]** key during the initial counting of the display after power turned on.
- The “**Weight**” display will show “**Pln** ” requesting the password number to be entered.
- The default password is “**0000**” but other numbers can be set using the parameter menus. Press the **[0]** key four times.
- Press the **[Tare]** key.
- The Parameter menu has 6 functions that can be accessed using the **[U. Wt./Units]** key to cycle through the choices. The “**Weight**” display will show the name of the functions. To enter a function, press the **[Tare]** key.
- At any time press the **[Zero]** key to return to weighing.

Weight Display	Description
<b>F1 CAL</b>	See the calibration section for details.
<b>F2 dl</b>	Set the scale increment. Press the <b>[U. Wt./Units]</b> key to cycle through the options (1,2,5,10). Press <b>[Tare]</b> to accept the selection.
<b>F3 Cnt</b>	Displays the A/D counts. Press <b>[Tare]</b> to return to menu.
<b>F4 AU</b>	Press the <b>[U. Wt./Units]</b> key to show the options. Select automatic accumulation ( <b>Au on</b> ) when the scale becomes stable, Manual accumulation ( <b>Au off</b> ) or Continuous ( <b>P Cont</b> ), the user must press the <b>[M+]</b> key to accumulate data.
<b>F5 A2 n</b>	Press the <b>[U. Wt./Units]</b> key to show the options for the auto-zero range. The value can be set to 0.5d, 1d, 2d or 4d. This is normally set to 1d but can be increased to force the scale to zero if it is likely to have small amounts of material spilled on the platform while in use.
<b>F6 Pln</b>	Set a new password number. Display will show “ <b>Pln 1</b> ” Enter the new password number then press the <b>[Tare]</b> key. Display will change to “ <b>Pln 2</b> ”, Enter the password again and press <b>[Tare]</b> again. The display will show “ <b>done</b> ” to show the new password has been accepted. Record the new password number in a secure place.
<b>F7 SPd</b>	This is used to set the speed at which the scale will run the ADC. The fastest setting is 7.5 and the slowest and the most stable is 6.



## 8. CALIBRATION

- The CBC scales calibrate using metric weights and the CBCa scales can calibrate using either metric or pound weights, depending on the weighing unit in use before calibration.
- The scales will offer a value of the weight to be used for calibration, however you can enter a different value if desired.
- When the parameter menu shows "**F1 CAL**" press the **[Tare]** key.
- The display will then show "**unLoAd**" to request all weight be removed from the platform.
- Press the **[Tare]** key to set the zero point.
- The display will then show the calibration weight suggested. It is shown as a whole number, for example 5 is 5.000kg. Either put this weight on the platform and then press the **[Tare]** key after the stable symbol is on or enter the value desired and then press the **[Tare]** key. The display will show "**LoAd**". Place the weight on the platform and press the **[Tare]** key again.
- At all times the scale should be stable before pressing the **[Tare]** key to accept a weight. The stability indicator will turn on to show the value is stable.

CBCa scales will also have the lb or kg indicator on, to show the denomination of the weight requested. If the scale was in pounds before starting the calibration, the weights requested will be in pound values, or if the scale was weighing in kilograms then metric weights will be requested.

- When calibration is done the display will show the counting from 0 to 9 and then return to normal operation.
- If an error message “**Err 8**” is shown then re-check the calibration and repeat it if necessary.

**Suggested Calibration weights for CBC Series:**

<b>CBC SERIES</b>				
<b>Model #</b>	<b>CBC 3</b>	<b>CBC 6</b>	<b>CBC 15</b>	<b>CBC 30</b>
	2000g	5000 g	10 kg	20 kg

**Suggested Calibration Weights for CBCa Series:**

<b>CBCa SERIES</b>								
<b>Model #</b>	<b>CBC 6a</b>		<b>CBC 12a</b>		<b>CBC 35a</b>		<b>CBC 65a</b>	
	lb	kg	lb	kg	lb	kg	lb	kg
	5 lb	2000 g	10 lb	5000 g	30 lb.	10 kg	50 lb	20kg

- After calibration the scale should be checked to verify the calibration and linearity is correct.

If necessary repeat calibration, especially be certain the scale is stable before accepting any weight.

## 9. RS-232 OUTPUT

The CBC Series of scales can be ordered with an optional RS-232 output.

### Specifications:

RS-232 output of weighing data  
ASCII code  
4800 Baud  
8 data bits  
No Parity

### Connector:

9 pin d-subminiature socket  
Pin 3 Output  
Pin 2 Input, not used at this time  
Pin 5 Signal Ground

### Data Format-Normal Output

GS 1.234 Kg      GS for Gross weight, NT for net weight (with tare value stored)  
U.W. 123 g      Kg and g for metric and Lb for pounds.  
PCS 10 pcs  
<lf>              Includes 2 line feeds  
<lf>

### Data Format- Memory Recall Print

```
*****  
<lf>              Includes 1 line feed  
TOTAL  
No.      5  
Wgt 1.234 Kg      .  
PCS 10 pcs  
<lf>              Includes 1 line feed  
*****
```

## 10. BATTERY AND BACKLIGHT OPERATION

### 10.1 BATTERY

- The scales can be operated from the battery, if desired. The battery life is approximately 70 hours.
- When the battery needs charging the arrow above the low battery symbol under the “**Weight**” display will turn on. The battery should be charged as soon as the arrow above the symbol is on. The scale will still operate for about 10 hours after which it will automatically switch off to protect the battery.
- To charge the battery, simply plug the power supply module into the scale and switch the main power ON. The scale does not need to be turned on.
- The battery should be charged for 12 hours for full capacity.
- Just under the “**Count**” display is an LED to indicate the status of battery charging. When the scale is plugged into the main power, the internal battery will be charged. If the LED is green the battery is fully charged. If it is red the battery is nearly discharged and yellow indicates the battery should be charged longer, preferably overnight.
- If the battery has not been used properly or it is used for a number of years it may eventually fail to hold a full charge. If the battery life becomes unacceptable then contact your distributor or Adam Equipment.

## 10.2 BACKLIGHT FOR LCD

- The backlight of the LCD can be set to be on full time, only when a weight is on the scale or can be turned off.
- To set the backlight press and hold the **[Pst]** key for 4 seconds.
- The weight display will show “**EL xx**” where **xx** is the current setting for the backlight.
- Press **[U. Wt./Units]** to set the parameter.

“ <b>EL Au</b> ”	Sets the backlight to operate automatically when a weight is placed on the scale or a key is pressed.
“ <b>EL Off</b> ”	Sets the backlight to be off.
“ <b>EL On</b> ”	Sets the backlight to be on at all times.

- Press the **[Tare]** key to store the value or press the **[Zero]** key to escape from this setting and return to weighing.

## 11. ERROR CODES

During the initial power-on testing or during operation it is possible that the scale may show an error message. The meaning of the error messages is described below.

If an error message is shown, repeat the procedure that caused the message, turning the balance on, carry out the calibration or other functions. If the error message is still shown contact your dealer for further support.

ERROR CODE	DESCRIPTION	POSSIBLE CAUSES
<b>Err 4</b>	Initial Zero is greater than allowed (typically 4% of the maximum capacity) when power is turned on or when the <b>[Zero]</b> key is pressed,	Weight is on the pan when turning the scale on.  Excessive weight on the pan when zeroing the scale.  Improper calibration of the scale.  Damaged load cell.  Damaged Electronics.
<b>Err 5</b>	Keyboard Error.	Improper operation of the scale.
<b>Err 6</b>	A/D count is not correct when turning the scale on.	Platform is not installed.  Load cell is damaged.  Electronics is damaged.
<b>Err 8</b>	Calibration Error	Improper calibration.  The scale is not stable.



### **Manufacturer's Declaration of Conformity**

This product has been manufactured in accordance with the harmonised European standards, following the provisions of the below stated directives:

Electro Magnetic Compatibility Directive 89/336/EEC

Low Voltage Directive 73/23/EEC

Adam Equipment Co. Ltd.  
Bond Avenue  
Denbigh East Estate  
Milton Keynes, MK1 1SW  
United Kingdom

### **FCC COMPLIANCE**

This equipment has been tested and found to comply with the limits for a Class A digital device, pursuant to Part 15 of the FCC Rules. These limits are designed to provide reasonable protection against harmful interference when the equipment is operated in a commercial environment. The equipment generates, uses, and can radiate radio frequency energy and, if not installed and used in accordance with the instruction manual, may cause harmful interference to radio communications. Operation of this equipment in a residential area is likely to cause harmful interference in which case the user will be required to correct the interference at his own expense.

Shielded interconnect cables must be employed with this equipment to insure compliance with the pertinent RF emission limits governing this device.

Changes or modifications not expressly approved by Adam Equipment could void the user's authority to operate the equipment.

**ADAM EQUIPMENT** is an ISO 9001:2002 certified global organisation with more than 30 years experience in the production and sale of electronic weighing equipments. Products are sold through a world wide distributor network -supported from our company locations in the UK, USA and SOUTH AFRICA. The company and their distributors offer a full range of Technical Services such as on site and workshop repair, preventative maintenance and calibration facilities.

**ADAM's** products are predominantly designed for the Laboratory, Educational, Medical and Industrial Segments. The product range can be classified as follows:

- Analytical and Precision Laboratory Balances
- Top Loading Balances for Educational establishments
- Counting Scales for Industrial and Warehouse applications
- Digital Weighing/Check-weighing Scales
- High performance Platform Scales with extensive software features including parts counting, percent weighing etc.
- Digital Electronic Scales for Medical use
- Retail Scales for price computing

<p><b>Adam Equipment Co. Ltd.</b> Bond Avenue Milton Keynes MK1 1SW UK</p> <p>Phone:+44 (0)1908 274545 Fax: +44 (0)1908 641339</p> <p>e-mail: <a href="mailto:sales@adamequipment.co.uk">sales@adamequipment.co.uk</a></p>	<p><b>Adam Equipment Inc.</b> 26, Commerce Drive Danbury, CT 06810 USA</p> <p>Phone: +1 203 790 4774 Fax: +1 203 792 3406</p> <p>e-mail: <a href="mailto:sales@adamequipment.com">sales@adamequipment.com</a></p>	<p><b>Adam Equipment S.A. (Pty) Ltd.</b> P.O. Box 1422 Kempton Park 1620 Johannesburg Republic of South Africa</p> <p>Phone +27 (0)11 974 9745 Fax: +27 (0)11 392 2587</p> <p>e-mail: <a href="mailto:sales@adamequipment.co.za">sales@adamequipment.co.za</a></p>
--	---	--

© Copyright by Adam Equipment Co. Ltd. All rights reserved. No part of this publication may be reprinted or translated in any form or by any means without the prior permission of Adam Equipment.

Adam Equipment reserves the right to make changes to the technology, features, specifications and design of the equipment without notice.

All information contained within this publication was to the best of our knowledge timely, complete and accurate when issued. However, we are not responsible for misimpressions which may result form the reading of this material.

The latest version of this publication can be found on our Website.

Visit us at [\*\*www.adamequipment.com\*\*](http://www.adamequipment.com)